

Sewer Manhole

CONCRETE PRODUCTS

Terry Lane
Glocester, RI 02814
(401) 568-8874

PRODUCT CODE CPSMH

DESIGN NOTES:

- KOR-n-SEAL joint the exceeds A.S.T.M. C923 specifications.
- EPDM rubber compound offers superior resistance to elements.
- Korband and Pipe Clamps are non-magnetic series 304 stainless steel to achieve maximum corrosion resistance.



SIDE VIEW

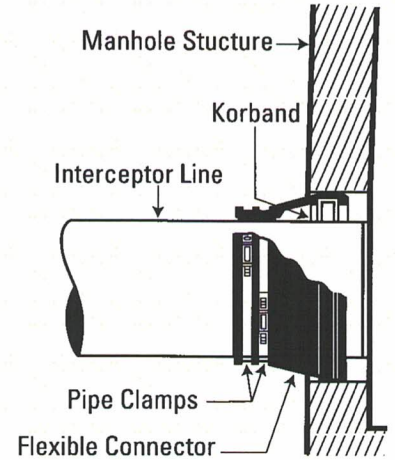
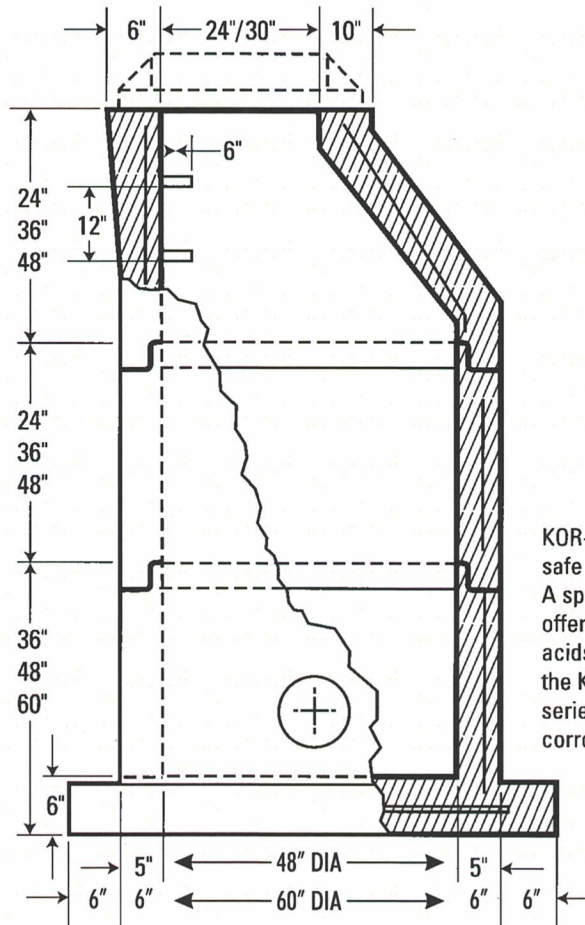

Kor-N-Seal cut-away

KOR-N-Seal is a flexible, watertight, environmentally safe joint that exceeds A.S.T.H. C923 specifications. A specially formulated EPDM rubber compound offers superior resistance to weather, ozone, oils acids, alkalis, and animal and vegetable fats. Both the Korband and the Pipe Clamps are non-magnetic series 304 stainless steel to achieve maximum corrosion resistance.

DESIGN SPECIFICATIONS CONFORM TO: "PRECAST REINFORCED CONCRETE MANHOLE SECTIONS – A.S.T.M. DESIGNATION C478, LATEST REVISION."

- Joint sealant shall be preformed butyl rubber mastic type seal that complies with AASHTO Specification M-198 or synthetic rubber gasket that complies with ASTM C443 or C361.
- Reinforcing A.S.T.M. A185 Area 0.21 in. vertically ft. Reinforcing in bell & spigot.
- Concrete compressive strength 4000 P.S.I. Type II cement.
- Base Section will be cast monolithic.
- Manhole Steps are made of co-polymer polypropylene. This material conforms to A.S.T.M. 4P01-82 PP200B33450Z02. (The previous standard of A.S.T.M. 2146-82, Type II Grade 43758 was replaced by D4101-82).
- Method of manufacture: Wet cast.

Pre-cast Bulkheads, Steps and Septic Tanks